

# A Series Storage Assist Vehicle

with capacity of 215kg

LI-ION  
TECHNOLOGY

INNOVATIVE LITHIUM-ION



*The World of Hangcha*

  
**HANGCHA**

# A SERIES STORAGE ASSIST VEHICLE

With a comprehensive safety protection system, excellent ergonomic design, an advanced control system and excellent performance, the vehicle is reliable, stable, comfortable and safe, and may be used for picking, transportation and other operations in narrow, low environments such as small warehouses, supermarkets, laboratories, etc.



SMALL WAREHOUSE



SUPERMARKETS



LABORATORIES

## Reliability

- / With a high-strength steel frame structure, the vehicle frame is robust and reliable.
- / All wires and cables have reliable protection, which greatly improves the reliability of the electrical system.
- / Switches, connectors, instruments and other key parts are all of leading international brands and have excellent performance and reliable quality.

## High performance

- / A green and environmentally friendly, efficient energy-saving CATL lithium battery is provided for the standard configuration.
- / An integrated charger enables easy and quick charging.
- / For the standard configuration a load tray and platform tray that can be lifted manually/electrically are provided to enable higher picking and transportation efficiency.
- / The maintenance-free brushless AC walking motor has excellent acceleration performance and low heat generation.



The advanced AC control system performs accurate, stable and efficient control. The CANBUS bus structure makes the communication of the vehicle faster and more reliable.



**SIMPLE/SOLID/  
SMART**



# ADDED SECURITY. THE SCIENCE OF DESIGN

## Comfort

- / The mast ascending and descending buffering function offers more comfort.
- / An optional tray that can be lifted electrically can be operated easily, stably and comfortably.
- / Multi-layer pedal pads and door pads reduce operator fatigue.
- / For the standard configuration, multi-function instruments have multiple functions such as mode selection, wheel position display, etc., and can clearly display various information of the vehicle.



Right and left hand sensing



Front and rear flashing lights

## Safety

- / The right and left hand sensing and safety pedal ensure the operator is in the correct operating position.
- / For the standard configuration a tilt switch sensor and a door guardrail sensing switch are provided to improve the operation safety.
- / The driving speed is correlated with lifting height, the higher the lifting height, the lower the driving speed and the correspondingly smaller the acceleration.
- / The turning proportional deceleration function provided for the standard configuration ensures smooth and safe turning.
- / The manual emergency descending function can be performed at the rear of the vehicle.
- / With the operating platform bottom safety protection, front and rear flashing lights and other functions, the surrounding personnel can be alerted and protected, and the driving danger can be reduced.

## Maintenance

- / The maintenance-free brushless AC motor significantly reduces the operating cost.
- / The integrated battery display, timer and fault self-diagnosis gauge facilitate maintenance.
- / All components are placed at the front of the frame, so just open the hood, and then the vehicle can be repaired easily and quickly.



A lower operation panel is designed to enable the operations such as operation platform lifting, brake release, etc. to be performed outside the vehicle so as to facilitate vehicle maintenance.

## Options

- / Blue light
- / Warning light
- / Front working light
- / Side roller
- / Electric lifting pallet
- / Back cushion



## A Series Storage Assist Vehicle Specification

Distinguishing mark	1.1	Manufacturer		HANGCHA GROUP CO.,LTD.
	1.2	Model		CJ002+MC-M11
	1.5	Rated capacity on load tray	Q(kg)	100
		Rated capacity on load deck	Qz(kg)	115
1.6	Rated capacity on standing platform	Qz(kg)	135	
	Wheelbase	y(mm)	1025	
Weight	2.1	Service weight	kg	600
	Tyres/chassis	3.1	Tyres: solid rubber, superelastic, pneumatic, polyurethane	
3.2		Tyre size, front	mm	0210-03
3.3		Tyre size, rear	mm	0280-60
3.5		Wheels, number driving, caster/loading (x=drive wheels)		1x/2
4.2		Height, mast lowered	h(mm)	1414
Dimensions	4.4	Lift	h2(mm)	2955
	4.5	Height, mast extended	h3(mm)	4409
	4.8	Seat height/standing height	h7(mm)	300
	4.10	Overall length	l(mm)	1625
	4.21	Overall width	b1/b2(mm)	750/750
	4.31	Ground clearance, centre of wheelbase	m2(mm)	40
	4.35	Turning radius	W2(mm)	1210
	Performance data	5.1	Travel speed,laden/unladen	km/h
5.2		Lift speed,laden/unladen	mm/s	260/300
5.3		Lowering speed,laden/unladen	mm/s	250/250
5.7		Gradeability,laden/unladen	%	5
5.10		Service brake		Electromagnetic
Electric-engine		6.1	Drive motor rating S2 60 min	kw
	6.2	Lift motor rating at S3 15 %	kw	2.2
	6.4	Battery voltage/nominal capacity K3, Maintenance free	V/Ah	24/125
		Type of battery		Lithium
Additional data	10.7	Sound pressure level at the driver's seat	dB(A)	68

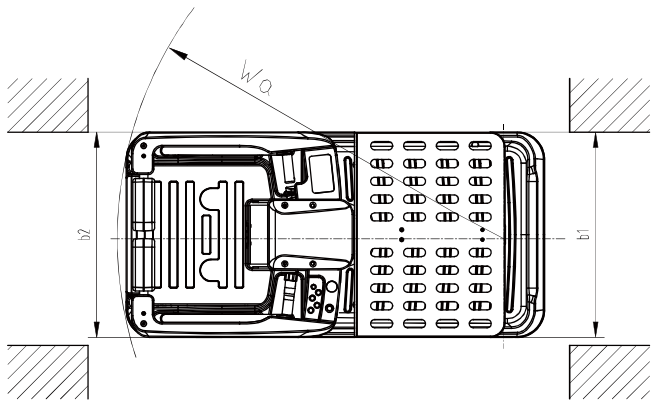
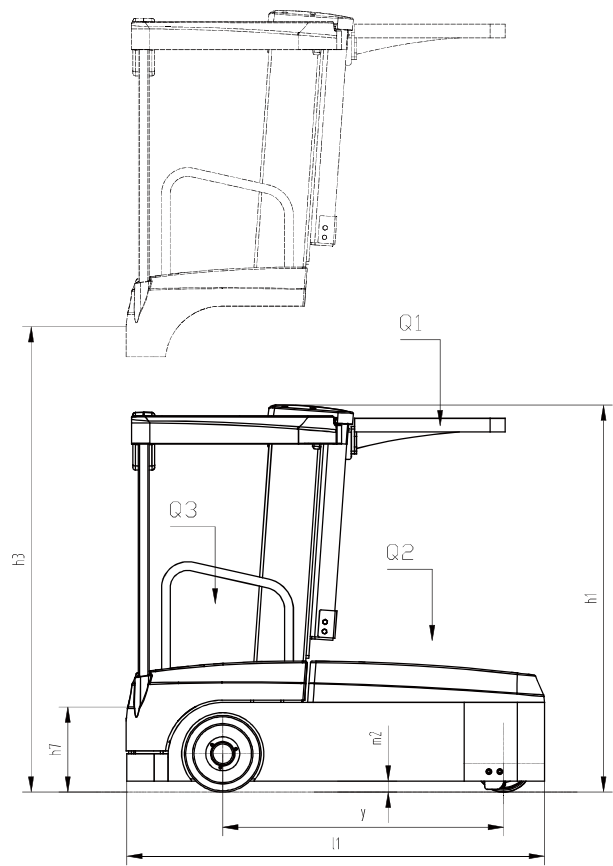



ZHEJIANG HANGCHA IMP. & EXP. CO., LTD.

Factory site: 666 Xiangfu Road,  
Hangzhou, Zhejiang, China (311305)

Tel: +86-571-88926735 88926755  
Fax: +86-571-88926789 88132890

sales@hcforklift.com  
www.hcforklift.com



Follow us on  
Facebook



Follow us on  
YouTube



Follow us on  
WeChat



Download "Hangcha  
Forklift" App



ISO14001  
ISO14001:2015



ISO9001  
ISO9001:2015



HANGCHA trucks conform to  
the European Safety  
Requirements.

HANGCHA GROUP CO., LTD. reserves the right to make any changes without notice concerning colors, equipment, or specifications detailed in this brochure, or to discontinue individual models. The colors of trucks, delivered may differ slightly from those in brochures.