

## Articulating Booms

		HANGCHA GROUP CO.,LTD.		
		GTHZ120	GTHZ170	
1	Manufacturer			
2	Model			
3	Working height	m	11.95	16.75
4	Platform height	m	9.95	14.75
5	Horizontal height	m	7.00	9.3
6	Up and over height	m	4.77	7.1
7	Length	m	5.48	6.92
8	Length (storage)	m	3.74	5.4
9	Wheel base	m	1.65	2
10	Width	m	1.22	1.75
11	Height	m	1.99	2.09
12	Height (storage)	m	2.16	2.09
13	Basket size	m	1.20x0.77	1.20x0.77
14	Turning radius inside	m	1.55	2.0
15	Turning radius outside	m	3.25	4.30
16	Turning radius outside (basket)	m	3.34	5.6
17	Ground Clearance	m	0.10	0.15
18	Capacity	kg	200	200
19	Jib movement		±70°	±70°
20	Basket rotation		140°	140°
21	Turret rotation		350°	355°
22	Drive speed	km/h	6.00	4.5
23	Working speed	km/h	0.60	0.60
24	Gradeability	%	25%	22%
25	Maxi slope acceptable	%	3° or 5%	3° or 5%
26	Tires	m	0.60x0.19	0.60x0.19
27	Wheel steer		2	2
28	Wheel drive		2	2
29	Batteries (C5)	V/Ah	330.2x24	330.2x24
30	Weight	kg	6550	7030

### Size Range

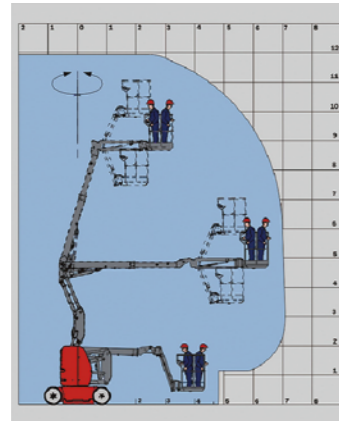
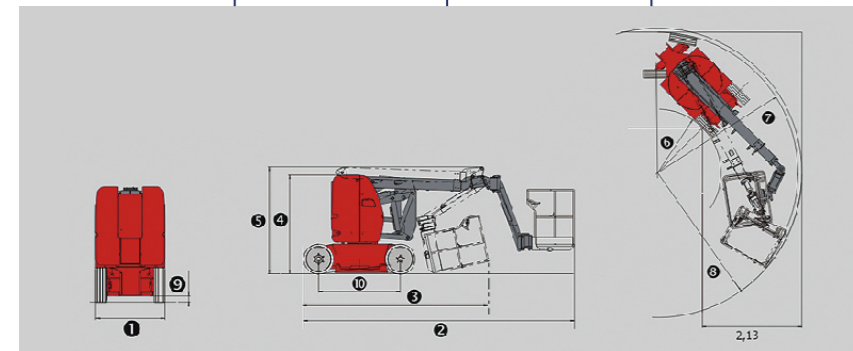

GTHZ120

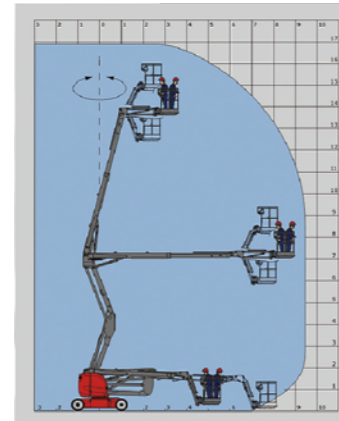

GTHZ170



ZHEJIANG HANGCHA IMP. & EXP. CO., LTD.

Factory site: 666 Xiangfu Road,  
Hangzhou, Zhejiang, China (311305)

Tel: +86-571-88926735 88926755  
Fax: +86-571-88926789 88132890

sales@hcforklift.com  
www.hcforklift.com



2018 VERSION, COPYRIGHT 2018/01



ISO14001  
ISO14001:2004



ISO9001  
ISO9001:2008



HANGCHA trucks conform  
to the European Safety  
Requirements.

HANGCHA GROUP CO., LTD. reserves the right to make any changes without notice concerning colors, equipment, or specifications detailed in this brochure, or to discontinue individual models. The colors of trucks, delivered may differ slightly from those in brochures.



## Articulating Booms

GTHZ120/GTHZ170

The World of Hangcha



## Articulating Booms

This machine has articulation boom which can work across the obstacle. It can carry two people and some tools in the basket. The machine allows you to operate it in limited place with narrow design and small radius turning system. You can operate the machine from basket or base control, so when you want to move it, you do not need to go down the machine. Multi-motion control allows you to operate several actions simultaneously. With this machine, you can do work more efficient and comfortable.



### Standard specification

- / Electrical battery traction
- / Negative brakes
- / Lifting brakes
- / Hour meter
- / Warning buzzer in the basket
- / 220V predisposal
- / Voltage indicator
- / Safety manual pump
- / Bus CAN technology
- / Diagnostic help integrated
- / Dual electrical motors
- / No marking tires
- / Anti-roll system
- / Integrated charger

### Options

- / Working lights
- / Flashing light(all motion alarm)
- / Buzzer
- / Air predisposal
- / Electrical plug 220V
- / Over-load sensor system

## Easy/ Efficiency/ Economy



GTHZ120



GTHZ170



Double rails baskets: Protect your hand. The floor of basket is with tight mesh, that can make you to observe the situation in the ground



2.Standard tracking battery: Reduce 40% of the charge time, raise 50% of the life time



The system anti-overturn

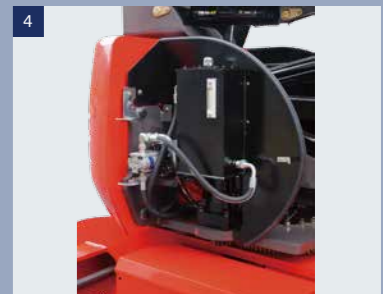

Motor, Motor of rotation



The main valve